

Surface Mount Super fast Recovery Rectifier

Reverse Voltage – 800 V

Forward Current – 8.0 A

FEATURES

- High current capability
- Low forward voltage drop
- Low power loss, high efficiency
- High surge capability
- High temperature soldering guaranteed

PINNING

PIN	DESCRIPTION
2,4	Cathode
1,3	Anode

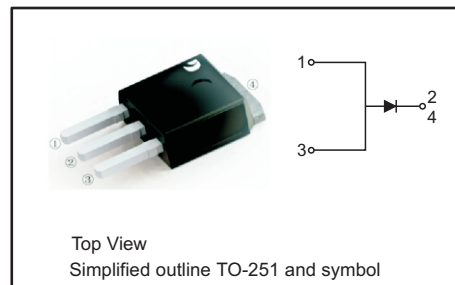

MAXIMUM RATINGS AND ELECTRICAL CHARACTERISTICS

Ratings at 25°C ambient temperature unless otherwise specified

Parameter	Symbols	SF808VYC	Units
Maximum Repetitive Peak Reverse Voltage	V_{RRM}	800	V
Maximum RMS voltage	V_{RMS}	560	V
Maximum DC Blocking Voltage	V_{DC}	800	V
Maximum Average Forward Rectified Current @ Fig.1	$I_{F(AV)}$	8	A
Peak Forward Surge Current, 8.3ms Single Half Sine-wave Superimposed on Rated Load (JEDEC method)	I_{FSM}	160	A
Peak Forward Surge Current, 1.0ms Single Half Sine-wave Superimposed on Rated Load (JEDEC method)	I_{FSM}	320	A
I^2t Rating for fusing (3ms ≤ t ≤ 8.3ms)	I^2t	106.2	A ² S
Max Instantaneous Forward Voltage at 8 A	V_F	2.5	V
Maximum DC Reverse Current at Rated DC Reverse Voltage $T_a = 25^\circ\text{C}$ $T_a = 125^\circ\text{C}$	I_R	1 300	μA
Typical Junction Capacitance ⁽¹⁾	C_j	109	pF
Maximum Reverse Recovery Time ⁽²⁾	t_{rr}	35	ns
Typical Thermal Resistance (without heat sink)	$R_{\theta JA}$ $R_{\theta JC}$ $R_{\theta JL}$	55 6 10	$^\circ\text{C/W}$
Operating and Storage Temperature Range	T_j, T_{stg}	-55 ~ +150	$^\circ\text{C}$

(1) Measured at 1 MHz and applied reverse voltage of 4 V D.C

(2) Measured with $I_F = 0.5\text{ A}$, $I_R = 1\text{ A}$, $I_{rr} = 0.25\text{ A}$.



Fig.1 Reverse Recovery Time Characteristic And Test Circuit Diagram

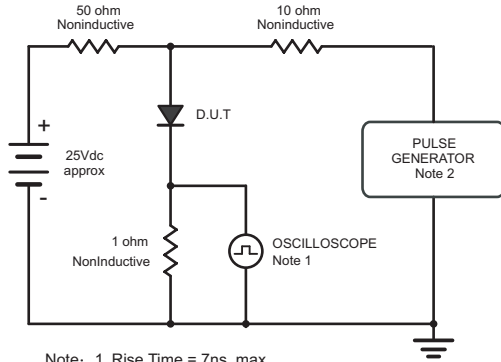

Note: 1. Rise Time = 7ns, max.
Input Impedance = 1megohm, 22pF.
2. Rises Time = 10ns, max.
Source Impedance = 50 ohms.

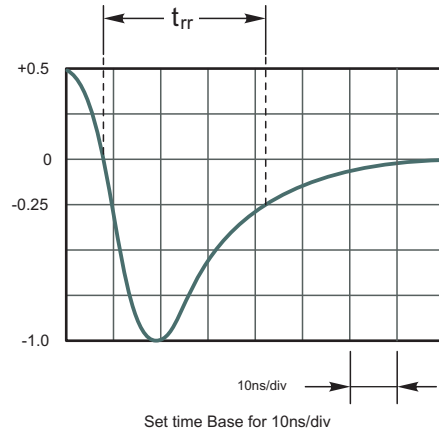

Fig.1 Maximum Average Forward Current Rating

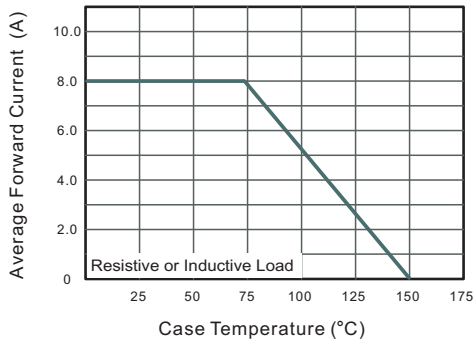

Fig.2 Typical Reverse Characteristics

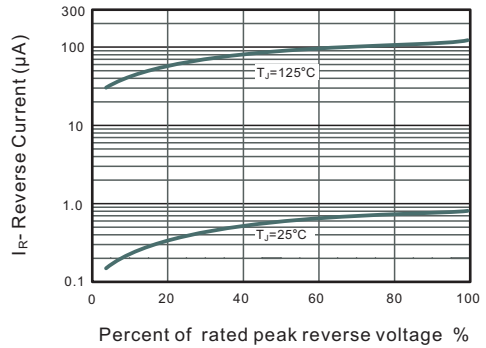

Fig.4 Typical Forward Characteristics

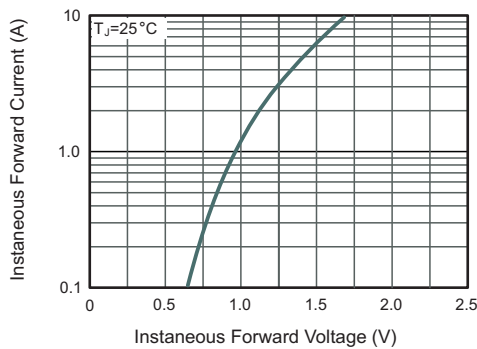

Fig.5 Typical Junction Capacitance

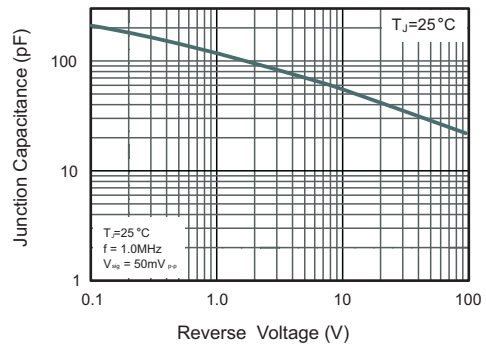
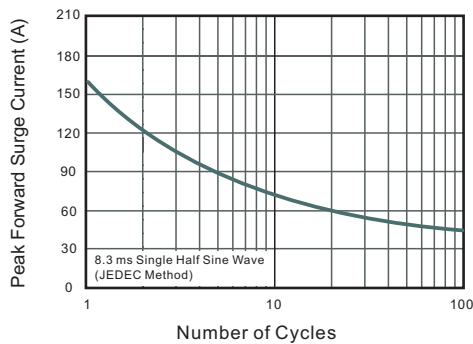

Fig.5 Maximum Non-Repetitive Peak Forward Surge Current





PACKAGE OUTLINE

Plastic surface mounted package; 3 leads

TO-251

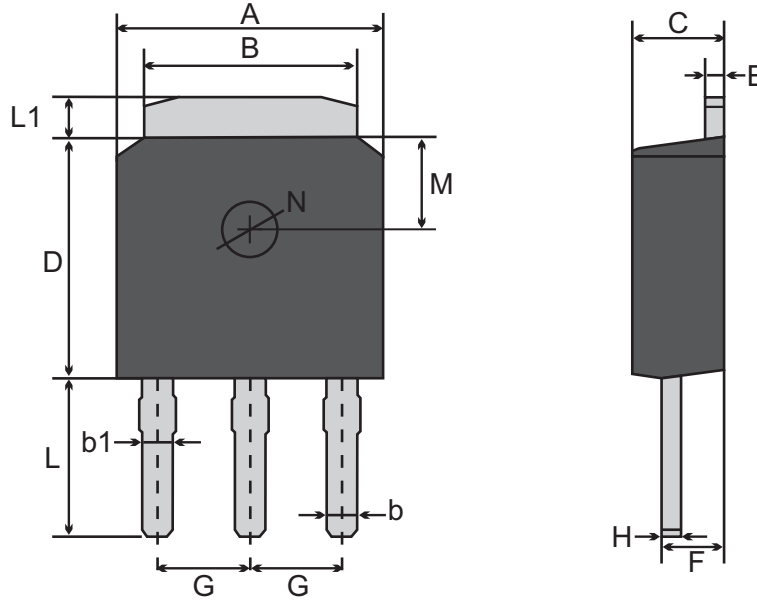

TO-251(I-PAK) mechanical data

UNIT		A	B	b	b1	C	D	E	F	G	H	L	L1	M	N
mm	max	6.7	5.5	0.86	0.9	2.5	6.3	0.6	1.8	2.29 TYPICAL	0.55	4.3	1.2	1.8 TYPICAL	1.3 TYPICAL
	min	6.3	5.1	0.66	0.76	2.1	5.9	0.4	1.3		0.45	3.9	0.8		
mil	max	264	217	33	35	98	248	24	71	90 TYPICAL	22	169	47	71 TYPICAL	51 TYPICAL
	min	248	201	26	30	83	232	16	51		18	154	31		

Marking

Type number	Marking code
SF808VYC	SF808VY



Important Notice and Disclaimer

Jingdao Microelectronics reserves the right to make changes to this document and its products and specifications at any time without notice.

Customers should obtain and confirm the latest product information and specifications before final design, purchase or use.

Jingdao Microelectronics makes no warranty, representation or guarantee regarding the suitability of its products for any particular purpose, nor does Jingdao Microelectronics assume any liability for application assistance or customer product design.

Jingdao Microelectronics does not warrant or accept any liability with products which are purchased or used for any unintended or unauthorized application.

No license is granted by implication or otherwise under any intellectual property rights of Jingdao Microelectronics.

Jingdao Microelectronics products are not authorized for use as critical components in life support devices or systems without express written approval of Jingdao Microelectronics.